

INSTRUCTION & MAINTENANCE MANUAL FOR MODEL # 73-800G

CAUTION: This device is powered by rotating electrical machinery !!!
Careless or improper use may result in personal injury. Read the Safety
Precautions and Warnings contained within **prior** to operating this machine.

READ AND SAVE THESE INSTRUCTIONS

SAFETY WARNINGS & CAUTIONS

FAILURE TO OBSERVE THE FOLLOWING PRECAUTIONS COULD RESULT IN SERIOUS INJURY, INCLUDING DEATH IN EXTREME CASES. SAVE THESE INSTRUCTIONS.

WARNING:(EXPLOSION HAZARD)

This unit contains parts which can arc or spark during normal operation. Do not use in areas contaminated by volatile or flammable materials as these sparks may ignite the contaminants and cause a dangerous explosion.

WARNING:(HARMFUL FUMES)

The filters used in this unit will remove solid particulate ONLY, and do not eliminate fumes and gases that may be a health hazard. Failure to observe the presence of such fumes could cause serious illness or death.

CAUTION:(SHOCK HAZARD)

To insure continued protection against shock hazard, connect A.C. cord only to properly grounded outlets. Replace defective cords immediately. Don't expose to moisture or liquid as this could defeat the electrical insulation thus causing electrical shock.

CAUTION:(STRONG VACUUM)

Care must be taken to avoid personal injury by not allowing hose inlet to contact any body area such as eyes, ears, mouth, etc.

CAUTION:(LIFTING)

Improper lifting or handling of this unit could cause back injury. Follow the recommended method for lifting.

CAUTION:(AIR FLOW BLOCKAGE)

Since exhaust air leaves the end of this unit, caution should be observed not to position unit in such a way as to block the exhaust.

MISCELLANEOUS CAUTIONS:

1. Use of any attachment not recommended or sold by the air cleaner manufacturer may result in risk of fire, electric shock, or injury to persons.
2. To reduce the risk of damage to the electric plug or cord, disconnect by pulling plug rather than cord when removing power from the air cleaner.
3. Make sure cord and hose are located so they will not be stepped on, tripped over, or otherwise subjected to damage or stress.
4. An extension cord should not be used unless absolutely necessary. Use of improper extension cord could result in risk of fire and electric shock.

NOTE: If extension cord must be used, use only a grounded cord and follow these recommendations:

- (25 ft. #12 AWG.)
- (50 ft. #10 AWG.)
- (100 ft. # 8 AWG.)

5. Do not disassemble the air cleaner. Take it to a qualified serviceman when service or repair is required. Incorrect reassembly may result in risk of electric shock or fire.
6. To reduce the risk of electric shock or bodily injury, unplug the air cleaner from outlet before attempting any maintenance or cleaning. Turning off the power switch will not eliminate this risk.

THEORY OF OPERATION

This unit is a portable air cleaner employing one thermally protected, high performance motor producing very high velocity air flow through the unit. Fine solid particulate material and smoke may be removed from the air by the filter media.

An initial spark trap collects large particles before they reach the pre-filter. This trap further isolates the filters from sparks in the case of a welding operation.

Upon leaving the trap, the air is passed through pre-filters. These pre-filters are designed to catch the larger particles leaving the trap. These relatively inexpensive pre-filters prevents the more expensive main filter from becoming quickly clogged. The pre-filters may be changed several times before the main filter needs to be changed.

All Factory furnished filters have a U.L. class II rating and using any filters other than those supplied for this unit is not recommended.

Use of any product other than that recommended by the manufacturer will void the warranty. The main (or final) filter may be selected from several grades available, depending upon the level of performance desired. All of these are high efficiency multi-flow filters which feature extended surface area for long life in high velocity filtration systems. See the Replacement Parts & Filters section toward the end of this manual for part numbers and filter efficiencies.

Selection of the filter best suited for the job should be discussed with a dealer or a factory representative.

A differential pressure gauge is an integral part of the unit. When the filters become clogged, the gauge will indicate an increase in differential pressure. At this point, the filters should be changed. Depending upon the application, the pre-filter can be changed several times before the main filter must be changed. Changing the pre-filters regularly can extend the useful life of the final filter up to 50%.

UNPACKING

Carefully inspect the unit for concealed damage that may have occurred during shipping and handling. If any damage is found, immediately contact the freight company. Make sure there are no dents in the housing, as they will prevent the filters from sliding into the units smoothly.

OPERATION

Your ACE Industrial Products machine is designed as a source capture device, i.e., it is intended to eliminate smoke and particulate at their point of origin. Keeping this in mind, the machine should be operated in the following manner:

Re-read the section on Safety Warnings & Cautions before proceeding any further.

1. Place the machine on a flat, level surface. Pick a location that will allow unrestricted flow of the exhaust air to the atmosphere.
2. For units with wheels or casters, lock the wheels or block the wheels.
3. Place the collection nozzle as close to the work as practical without interfering with the operator. Secure the nozzle if necessary.
4. Using the On/Off switch, turn the machine On. Should the motor not start, or should the machine make unusual noises, immediately turn the machine off and seek trained maintenance personnel. Do not continue to use the device.
5. Upon completion of the specific manufacturing or welding operation, turn the machine off. Continuous running of the air cleaner will reduce the life of the filters and increase utility costs.
6. When the differential pressure gage indicate that the filter(s) are clogged, turn the machine off and remove the power cord from its power source.

See the section on Installation and use the reverse process to remove the dirty filters. Re-install new filters and reconnect the machine to its power source.

GENERAL MAINTENANCE

ONLY QUALIFIED SERVICE TECHNICIANS SHOULD MAKE REPAIRS TO THIS UNIT.

DO NOT REPLACE THESE MOTORS WITH MOTORS OTHER THAN THOSE RECOMMENDED BY THE MANUFACTURER.

ASSEMBLY INSTRUCTIONS

1. Slip the end of the hose over the nozzle and secure it in place with the supplied band clamp. (See figure 1)
2. Make sure that the swivel seal is pulled up from the hose mounting base to cover the gap between the swivel base and the hose swivel. (See figure 2)
3. Un-bolt the handle from inside the unit and mount the handle on the side of the unit with the two 1/4"-20 hex bolts and lockwashers provided. (See figure 3) :

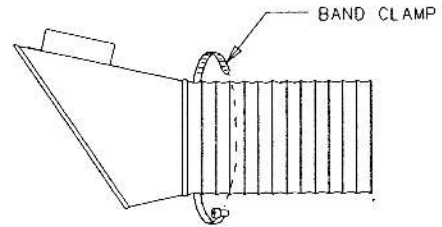

Figure 1

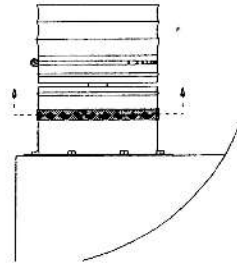

Figure 2

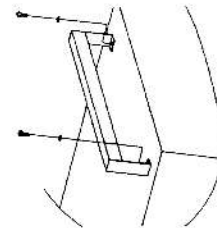

Figure 3

DUAL ARM UNIT OPTION

To install the second arm, proceed as follows:

1. Remove the blank plate covering the second hole. Save the hardware.
2. Using the hardware removed in Step 1 above, install the second collar to the unit.
3. Mount the second arm. (Look at replacement parts list for second arm option.)

SCHEMATIC WIRING DIAGRAM

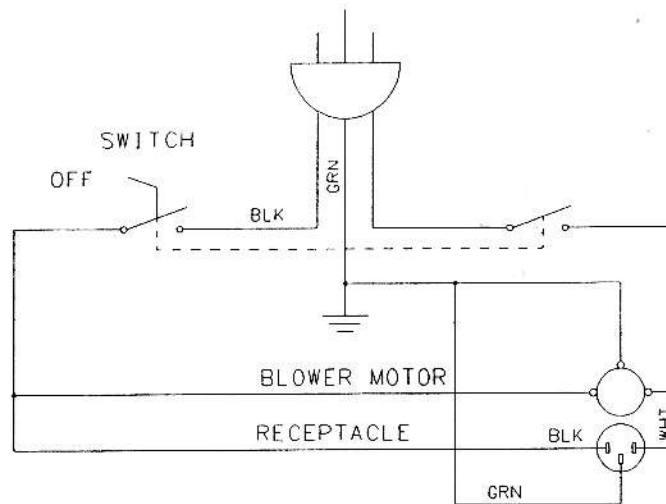

REPLACEMENT PARTS LIST

ITEM NUMBER	DESCRIPTION	SERVICE NUMBER
1	(MAIN FILTER)	
	95% EFFICIENT	91-952
	65% EFFICIENT	91-951
	40% EFFICIENT	91-950
2	(PRE-FILTER - 4" REQUIRED)	
	PRE-FILTER WRAP	91-962
	2"-10 SQ-FT SURFACE	91-955
	4"-19.4 SQ-FT SURFACE	91-956
	ALUMINUM MESH	91-958
3	HANDLE	65061
4	POWER SOCKET	65025
5	VACUUM GAUGE	65027
6	POWER SWITCH	65026

ITEM NUMBER	DESCRIPTION	SERVICE NUMBER
7	ARM ASSEMBLY	65028
	(INCLUDES HOSE AND BASE)	
8	REPLACEMENT HOSE	65029
	(HOSE ONLY)	
9	SWIVEL CASTER	65030
	(PKG. OF ONE)	
10	FIXED CASTER	65031
	(PKG. OF ONE)	
11	MOTOR	65024
12	BLOWER ASSEMBLY	65035
13	POWER CORD	65055
14	V-BELT	65034

EXPLODED VIEW

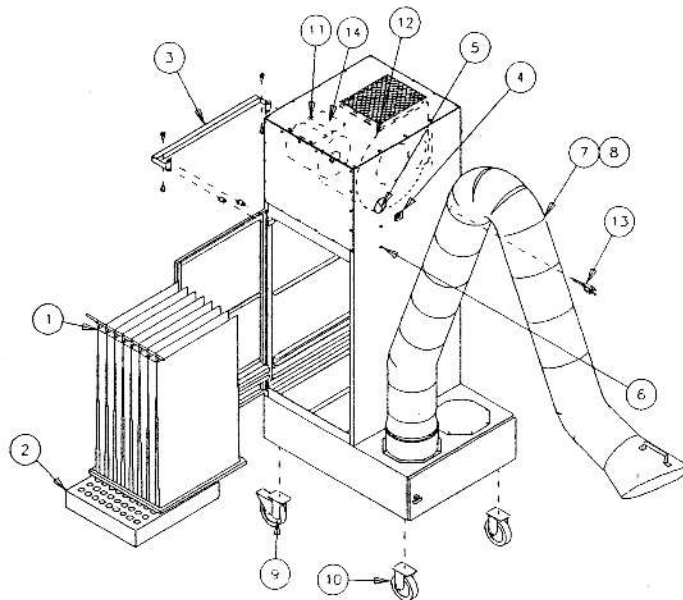

ACE INDUSTRIAL PRODUCTS

A Division Of:
 ASSOCIATED EQUIPMENT CORP.
 5043 Farlin Avenue
 St. Louis, MO. 63115
 PHONE: (314)385-5178
 FAX: (314)385-3254

W1954

REV. 7/97 027-0298