



ACE INDUSTRIAL PRODUCTS EASY REACH ARMS & ACCESSORIES INSTRUCTION MANUAL

GENERAL INFORMATION:

Check all packages for shipping damages. If any damage is found, then you as the receiver must note and contact the trucking Co. and file a claim. **THIS IS YOUR RESPONSIBILITY.**

CAUTION:

Some of these items are powered by a rotating electrical machinery!!! Careless or improper use may result in personal injury.

ASSEMBLY INFORMATION:

There will be some assembly required and the following will assist in the preparation for that assembly.

Arm assembly for wall/column mounting	Page 2-3
75-076 (7' arm)	
75-106 (10' arm)	
75-146 (14' arm)	
Arm assembly for direct duct mounting	Page 3
75-076D (7' arm)	
75-106D (10' arm)	
75-146D (14' arm)	
Boom/arm assembly	Page 3-5
75-100B (10' boom)	
75-107BA (10' boom with 7' arm)	
75-1010BA (10' boom with 7' arm)	
75-1014BA (10' boom with 7' arm)	
75-2014BA (20' articulated boom with 14' arm)	
75-500 and 75-675	Page 5
Wall mount extension.....	Page 5
75-803WM (3' extension)	
75-805WM (5' extension)	
75-807WM (7' extension)	
Ceiling mount extension.....	Page 6
75-803CM (3' extension)	
75-805CM (5' extension)	
75-807CM (7' extension)	
Floor mount extension.....	Page 6
75-803FM (3' extension)	
75-805FM (5' extension)	
75-807FM (7' extension)	
Connection flange	Page 6
75-800 (Connector - arm to duct)	
75-800D (Connector - arm to blower)	

ARM ASSEMBLY FOR WALL/COLUMN MOUNT

Please note that the arm support structure is inside a tube. The hose for the arm is on the outside of the tube. First remove the hose from the tube. Take care not to damage the hose. Patience is the best assurance. Secondly, remove the support structure from inside the tube. Each arm requires several components. Lay out the components to be sure that you have received all the correct components. See figure 1 for arm layout.

- A. Arm, complete with hood, hose & base.
- B. Swivel 90° elbow with mounted nylon pivot ring.
- C. Mounting bracket (Not used for arms on duct mount or booms)
- D. Bag of hardware
- E. 8 hole rubber gasket
- F. Connection flange (MODEL 75-800)

NOW YOU ARE READY TO ASSEMBLE AND ADJUST THE ARM. SEE ENCLOSED DRAWINGS AND INFORMATION.

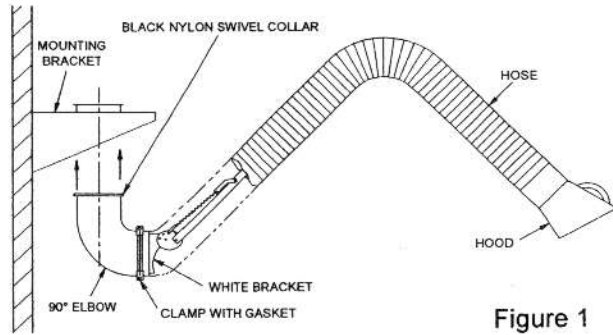

Figure 1

1. Locate your desired area to mount the arm. The support structure should be solid and fairly strong. Please note that the arm will develop stress on the support structure when the user pulls and positions the arm during use.
2. Using the mounting bracket, position the bracket on the support structure and, using a level, mark the holes in preparation for attaching the bracket. Be sure the bracket is as square and as level as you can make it. Use the level for this. Now mount the bracket and be sure it is secure.
3. Slide the hose away from the white base bracket. Please note there is a bolt with a red painted head. This bolt is in a hole marked [2]. Remove this bolt and pivot the white bracket 90 degrees so the hole marked [1] will line up with the hole in the bracket. Replace the red bolt and nut and bring to a snug fit. (See figure 2.)
4. Attach the 90° elbow to the white arm bracket. Note the elbow and the white bracket have a small mating flange. There is a rubber gasket that seals the flanges of the elbow and the white bracket. Install the steel metal clamp over the rubber gasket and flanges. BE SURE THAT THE ELBOW AND ARM ARE IN A PERFECT VERTICAL POSITION BEFORE TIGHTENING THE CLAMP. The arm should be vertical and the elbow is also vertical. (See figure 2).
5. With assistance, mount the assembled arm and elbow to the mounting bracket. The elbow has a mounted 8 hole black nylon swivel collar. Locate and bolt the arm, elbow, black nylon collar to the bracket by the 8 holes. Snug the bolts to hold the elbow to the mounting bracket. DO NOT OVER TIGHTEN THE BOLTS. Be sure elbow are swivel freely at the bracket.
6. The arm will need final adjustment/tuning for easiest movement and to stay in place upon positioning. You will find friction pads and adjustment pivot joints in four (4) places, 1) Pivot point at the white bracket, 2) Pivot point in the center of the arm. 3 & 4) Pivot points at the hood location. Only put enough tension on these pivot joints to hold the arm in any position it is placed. The arm final adjustment is key to the arm being user friendly. DO NOT OVER TIGHTEN THE PIVOT JOINT FRICTION DISKS. Depending on arm usage and movement, occasional adjustments may be required. Based on the arms application, cleaning of the internal support structure may require scheduled cleaning.
7. Extend the arm out and slide the hose over the arm. Clamp the hose to the white bracket using the clamp provided.
8. For attachment of the connection flange, see page 6 on connection flange assembly for MODEL 75-800.

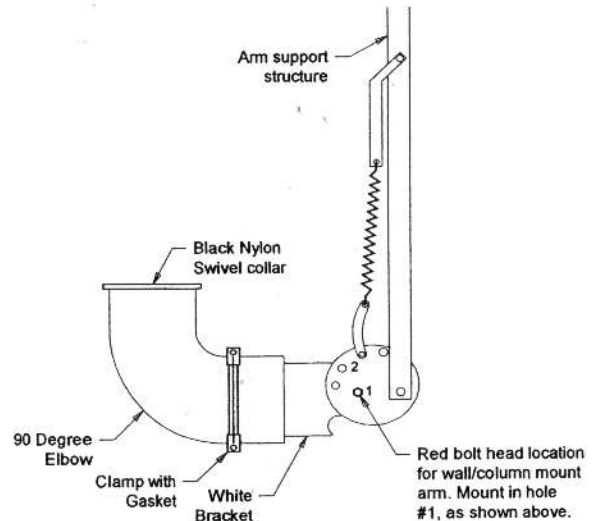

Figure 2

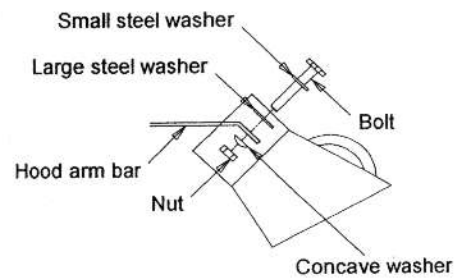

Figure 3

DIRECT DUCT MOUNTING ARM ASSEMBLY

Please note that the arm support structure is inside a tube. The hose for the arm is on the outside of the tube. First remove the hose from the tube. Take care not to damage the hose. Patience is the best assurance. Secondly, remove the support structure from inside the tube. The arm requires several components. Lay out the components to be sure that you have received all the correct components. See figure 4 for arm layout.

- A. Hose for arm
- B. Support structure
- C. Hood
- D. Swivel base
- E. Mounting bracket (Not used for arm on duct mount or booms)
- F. Bag of hardware
- G. 8 hole rubber gasket
- H. White 8 hole connection flange

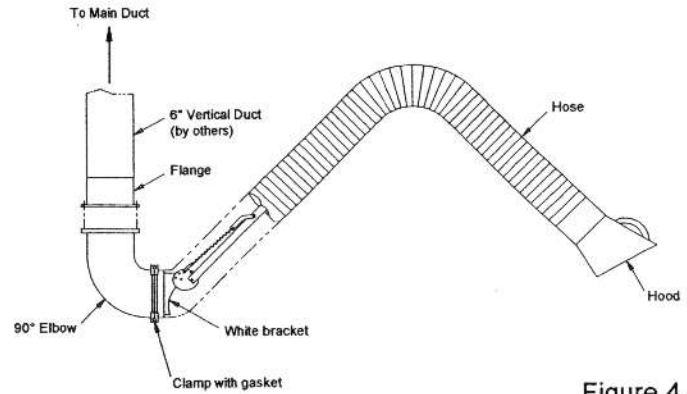

Figure 4

NOW YOU ARE READY TO ASSEMBLE AND ADJUST THE ARM. SEE ENCLOSED DRAWINGS AND INFORMATION.

1. Locate your vertical duct to mount the arm. The vertical support structure should be solid and strong. Please note that the arm will develop stress on the vertical duct structure when the user pulls and positions the arm during use.
2. Mount the connection flange to the vertical duct. Be sure the connection flange and the duct is solid.
3. Attach the swivel 90° elbow to the underside of the flange. Use the hardware supplied. Snug the swivel base to the flange evenly. There is no need to over tighten the swivel 90° elbow.
4. For assembly of the whole arm refer to the arm assembly on page 2.

BOOM ARM ASSEMBLY

There will be assembly required for the boom arm and the flex arm (if purchased with boom). Lay out the enclosed components and compare to the list and to figure 5, to be sure that you have received all the correct components. The boom arm components are in 2 long boxes. Remove the components and place in order as shown in figure 5. The flex arm (if purchased with boom) is packaged in a shorter box, refer to page 2 & 3 for the parts list and see figure 1 for the arm layout. **Note:** Mounting plate not included.

1. Flex hose
2. Hose clamps
3. Duct cradle (2)
4. Short spiral duct
5. Spiral duct splice fitting
6. Long spiral duct
7. 90° elbow
8. Solid steel pivot support pin
9. Steel mounting plate with friction brake
10. Boom mounting section
11. Thrust bearings
12. Threaded stud for duct cradle (2)
13. Boom extension section
14. Clamp profile with 6 bolts, tooth washer and nuts
15. Exhaust mounting support

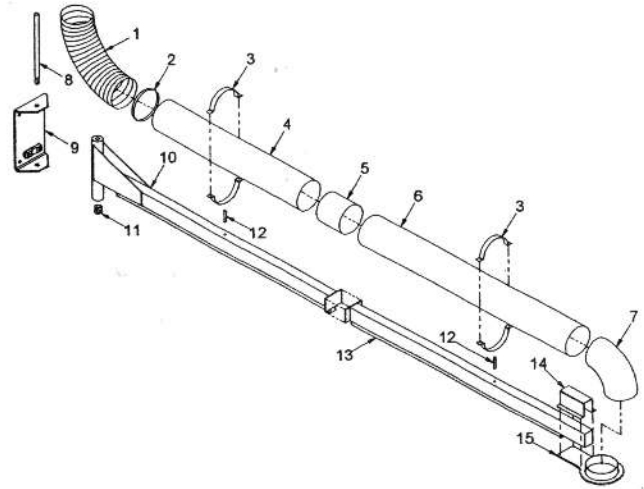

Figure 5

NOT SHOWN 4 bolts, lock tooth washers and nuts to secure boom sections.

NOW YOU ARE READY TO ASSEMBLE AND ADJUST THE ARM. SEE ENCLOSED DRAWINGS AND INFORMATION.

1. The steel mounting plate (wall/column bracket) is constructed to withstand a torque of up to 5500 ft. lbs. Be sure the support structure is designed to withstand the stress and strain that the boom/arm may develop under use.

THE FACTORY IS NOT RESPONSIBLE FOR ANY FAILURES OR DAMAGE CAUSED TO THE BOOM OR TO THE BUILDING STRUCTURE DUE TO INSTALLATION NEGLIGENCE.

2. Take the mounting plate and remove the steel, pivot rod by removing the small bolt and nut on the bottom of the rod. Please note that the mounting plate has a brown friction pad. This pad will assist you in telling top from bottom of the mounting plate. The friction pad and rod with bolt is the bottom of the bracket. Be sure to mount bracket as such. See figure 6.
3. Using a level, mount the bracket square and solid. Once you have mounted the bracket, recheck for squareness and strength. **BE SURE THE BRACKET IS PERFECTLY VERTICAL.**
4. Mount the first half of the boom arm with the groove on the bottom to the wall bracket. You should have noticed a flat washer and thick, steel thrust washer on the steel pivot rod when you removed the rod from the wall bracket. Be sure these thrust washers are installed on the underside of the boom. See figure 6. Slide pivot rod into the top of the mounting bracket and into the bearing on the boom and through the thrust washers and into the bottom of the mounting bracket. The rod has flat sides and the mounting bracket has matching flat sides. Be sure the rod slips completely into the flat sides. Install the small bolts and nuts and tighten snugly.
5. Install the second half of the boom arm to the first half and use the 4 large bolts, lock-tooth washers, and hex nuts. Tighten the bolts firmly.
6. Install the clamp profile to the exhaust arm mounting support using the 6 bolts, nuts, and lock tooth washers. Slip this assembly over the end of the boom end with the angle flange facing up. See figure 5. Slip over until the arm mounting support hits the groove channel. Tighten this assembly.
7. Install the threaded studs into the duct cradles. Be sure to install the flat threaded end into the cradle nut. Now install the assemblies into the top of the boom. You will find two threaded holes. Snug the assemblies to the boom. Remove upper half of the cradle so the duct can sit on the bottom half of the cradle.
8. Using a small amount of lubricant on the rubber seals, install the 90° elbow into the exhaust arm, mounting bracket.
9. Assemble the 6" spiral duct sections together to make one piece. Set the assembly into the lower half of the duct cradles. Slip the end of the assembly into the elbow. You may want to use a small amount of lubricant on the seals to ease the installation. Be sure the long spiral duct is installed in the elbow.
10. Once the duct assembly is completely sealed into the elbow, then install the upper half of the cradle and secure the cradles to the duct.
11. Clamp the flex hose to the 6" spiral duct.
12. If you purchased an arm, attach the swivel 90° elbow to the underside of the flange. Use the hardware supplied. Snug the swivel 90° elbow to the flange evenly. There is no need to over tighten the swivel base. For assembly of the whole arm refer to the arm assembly on page 2.

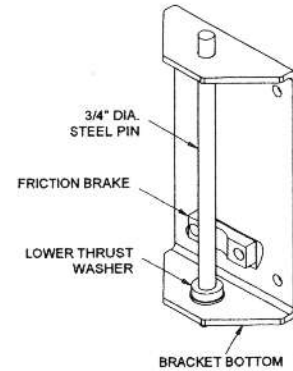

Figure 6

PIVOTING ARTICULATED CRANE ARM ASSEMBLY

Assembly of the crane and accessories will be required. The following will assist in preparation for the assembly. Layout the components for the boom arm and verify all the components have been received. {Refer to figure 7}

- A. Front crane beam and rear crane beam with mounting bracket.
- B. (2) Flex hoses. (1) @ 4' for center and (1) @ 5' at wall.
- C. (3) duct cradles for hard pipe.
- D. (3) Hose Clamps
- E. Front crane beam bumper stop mounted on end of rear crane beam.
- F. 90° elbow mounted to hard duct for front beam.

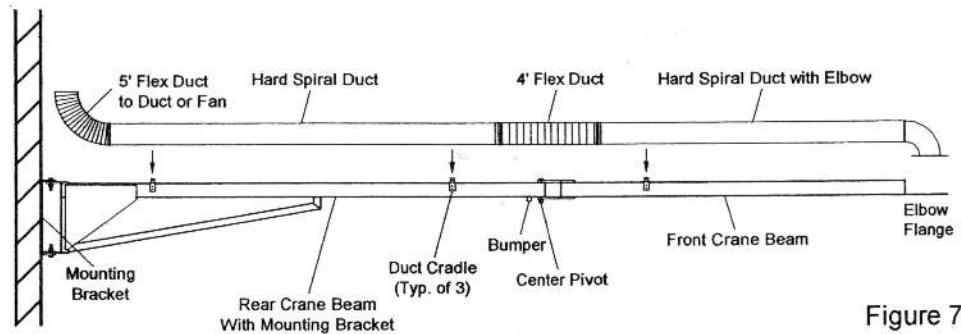

Figure 7

Please see the other sections that pertain to accessories that were ordered with the crane.

INSTALLATION

1. Support structure for the crane arm must be solid and secure. The structure to which the crane arm will be mounted should be carefully reviewed for its strength. If there is any question or doubt about the structure, a structural engineer or other experienced person should be consulted.

RESPONSIBILITY AND LIABILITY OF SUCH SUPPORT STRUCTURE IS SOLELY UPON THE PERSON(S) SELECTING SUCH SUPPORT STRUCTURE.

2. After selection of the support structure, a decision on how the main support bracket of the crane arm should be installed. The mounting bracket must be installed perfectly vertical to prevent drifting of the crane arm. Depending upon installation equipment, it may be determined that the bracket should be removed from the crane arm and installed to ensure the vertical accuracy of the bracket. Bracket can then be attached back onto the crane arm. All hardware must be reinstalled exactly as original. {See figure 8}. Tighten hardware sufficiently enough so crane arm swings firmly yet freely.
3. See figure 9 for center pivot hardware assembly.

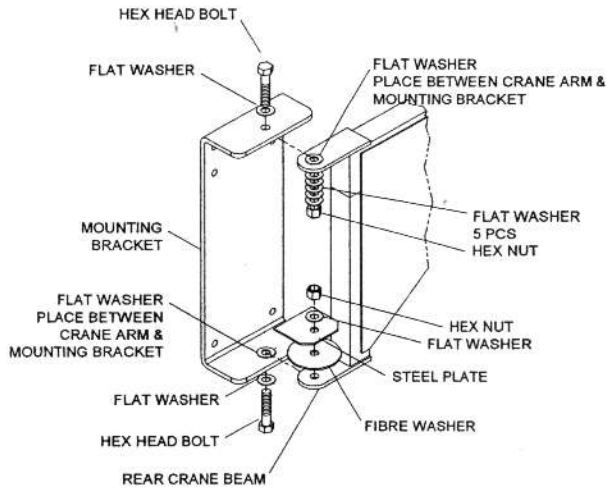

Figure 8

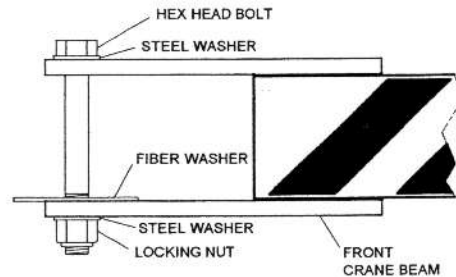

Figure 9

4. Determination if crane arm is to be installed in sections or as an assembly is based upon what type of equipment is available at installation site.
5. Center hard spiraled duct over rear beam duct cradles. Using a 3/16 bit, drill holes into the duct using pre-drill holes in the cradles as guides. Secure with the supplied self tapping screws. Install hard spiral with elbow onto the front beam. Put elbow into the elbow flange and set hard duct onto cradle. Using the 3/16 bit, drill holes into duct and the elbow using pre-drilled holes in cradle and elbow flange as guides. Secure with the supplied self tapping screws. Install the 4' flex hose in center pivot point and secure with clamps. Install the 5' flex hose to hard duct at wall mount bracket. Hose at the wall mount bracket will either clamp to a vertical duct branch, or to an optional blower and bracket if so supplied.

75-500 and 75-675

Please note that the arm support structure is inside a tube. The hose for the arm is on the outside of the tube. First remove the hose from the tube. Take care not to damage the hose. Patience is the best assurance. Secondly, remove the support structure from inside the tube. The kit requires several components. Lay out the components to be sure that you have received all the correct components. See figure 1 for arm layout and figure 11 for blower/motor layout.

1. For instruction on mounting the arm, refer to page 2, (instructions 1 - 11) on assembly for wall/column mount.
2. For instructions on connecting flange, blower, and motor. Refer to the section on page 7, on connection flange assembly, **MODEL 75-800D.**

WALL MOUNT EXTENSION BRACKET

MODELS: 75-803WM, 75-805WM and 75-807WM

See figure 10

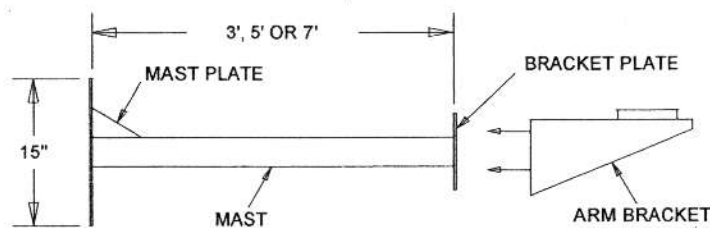

Figure 10

CEILING MOUNT EXTENSION BRACKET

(MODEL 75-803CM, 75-805CM, 75-807CM)

See figure 11

FLOOR MOUNT EXTENSION BRACKET

(MODEL 75-803FM, 75-805FM, 75-807FM)

See figure 12

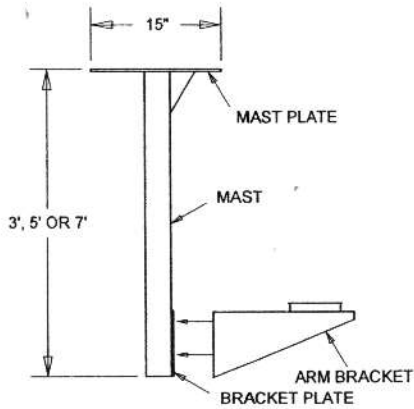

Figure 11

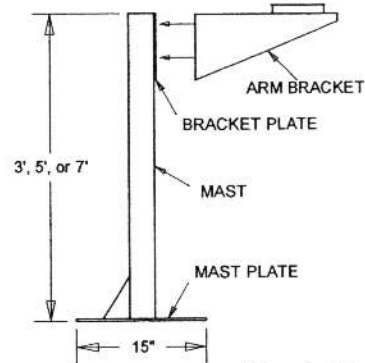

Figure 12

1. Locate the desired area to mount the extension bracket. The support structure should be solid and strong. Please note that this assembly will develop stress on the support structure when the user pulls and positions the arm during use.
2. Using the extension bracket, position the mast plate to the support structure and, using a level, mark the holes in preparation for attaching the bracket. Be sure the bracket is as square and as level as you can make it. Use the level for this. Now mount the bracket and be sure it is secure.
3. To mount the arm, refer to arm assembly on page 2.

CONNECTION FLANGE ASSEMBLY

MODEL 75-800 (Connecting arm to duct)

1. Notice the mounting bracket for the arm has a connection flange with a rolled lip on the top.
2. In order to use a 6" connecting duct to the main duct from the arm, **MODEL 75-800** connection flange and snap ring are required. See figure 13. The connection flange and the snap ring mount directly to the mounting bracket.
3. Open the snap ring fully and set it over the mounting bracket rolled lip flange. Then set the flange on top the rolled lip and slide the snap ring up and lock the flange to the rolled lip.
4. Now the 6" duct can be attached to the arm so the connection from the arm to the main duct can be completed.
5. **NOTE: Hard duct is preferred over flex pipe from arm to main duct.**

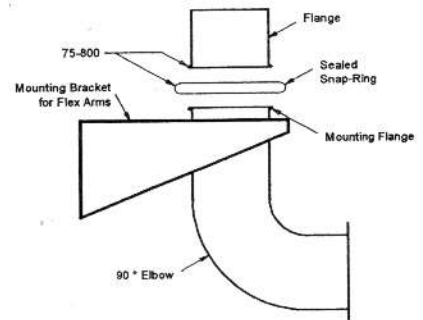

Figure 13

MODEL 75-800D (Connector - arm direct to blower)

1. Notice the mounting bracket for the arm has a connection flange with a rolled lip on the top.
2. In order to use a blower (blower with 4 studs on the inlet side) connecting to the mounting bracket from the arm, **Model 75-800D** connection flange and a snap ring are required. This is a funnel type fitting that is to be bolted directly the fan inlet. See figure 14.
3. Open up the snap ring fully and set it over the mounting bracket rolled lip flange. Then place the blower with the flange on top the rolled lip and slide the snap ring up and lock the flange to the rolled lip.
4. The fan discharge can be positioned at any point around a 360 degree circle.
5. **NOTE: Hard duct is preferred over flex pipe from fan discharge to main duct.**

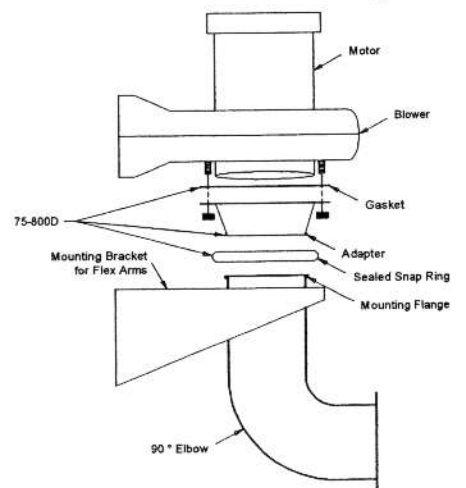

Figure 14

Please contact your local distributor or **ACE INDUSTRIAL PRODUCTS** for any assistance you may need. Like any equipment, your arm will give good long life with proper care and maintenance.

ACE INDUSTRIAL PRODUCTS IS NOT RESPONSIBLE FOR ANY FAILURES OR DAMAGE CAUSED TO THE BOOM, ARM, OR TO THE BUILDING STRUCTURE DUE TO INSTALLATION NEGLIGENCE.

ACE INDUSTRIAL PRODUCTS
A Division of Associated Equipment Corporation
5043 Farlin Avenue. St. Louis, MO 63115
Tel. (314) 385-5178 Fax. (314) 385-3254
www.aceindustrialproducts.com